

Istruzioni per il montaggio

krila[®]
design

AVVERTENZE:

- L'INSTALLAZIONE E LA MANUTENZIONE DELL'APPARECCHIO DEVONO ESSERE EFFETTUATE DA PERSONALE SPECIALIZZATO.
- LA SICUREZZA DELL'APPARECCHIO E' GARANTITA SOLO CON L'USO APPROPRIATO DELLE SEGUENTI ISTRUZIONI, PERTANTO E' NECESSARIO CONSERVARLE.
- TOGLIERE LA TENSIONE PRIMA DI EFFETTUARE QUALSIASI TIPO DI MANUTENZIONE.
- LA BASE ED ALTRE PARTI DELL'APPARECCHIO NON DEVONO ESSERE RICOPERTE DAL TERRENO O VENIRE A CONTATTO CON SOSTANZE CHIMICHE AGGRESSIVE (DISERBANTI, FERTILIZZANTI, ECC).
- NON APPOGGIARE OGGETTI SULLO SCHERMO, NON OSCURARLO O COPRIRLO IN ALCUN MODO.
- PULIRE PERIODICAMENTE LE PARTI RICOPERTE DA ACCUMULI DI TERRA.
- UTILIZZARE CAVO DI ALIMENTAZIONE IN DOPPIA GUAINA, NON UTILIZZARE CAVI SINGOLI.
- UTILIZZARE SOLO CAVI FLESSIBILI TIPO <HAR> O IDONEI PER UN UTILIZZO IN ESTERNO.
- E' OBBLIGATORIO IL COLLEGAMENTO DEL CAVO DI TERRA ALL'APPOSITO MORSETTO DELL'APPARECCHIO E AL CIRCUITO DI TERRA DELL'IMPIANTO ELETTRICO.

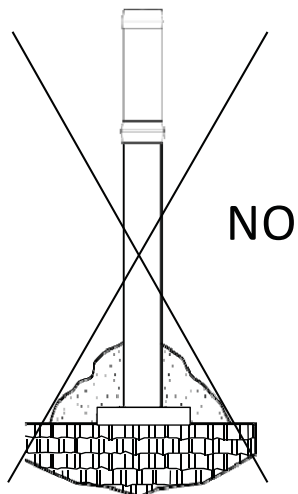
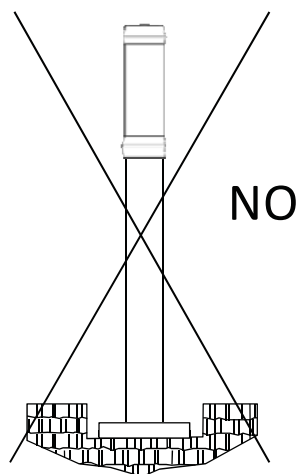

IP65      

I prodotti sono coperti da brevetto
Products are covered by patent

Online

Cod.5016/5017/5018/5019
ONLINE d.70 (h550/690/1000/1500)
Colonnina da esterno
Outdoor lamp

Istruzioni per l'installazione

- Svitare le ghiera (1;2)
- Inserire il cavo di alimentazione (3) nelle ghiera (1;2)
- ATTENZIONE:** utilizzare cavo d.7/12 mm, se si utilizza un cavo di diametro superiore a 9 mm rimuovere la guarnizione interna delle due presenti (4) nel pressacavo
- Collegare il cavo di alimentazione (4) rispettando le polarità
- Chiudere la morsettiera stagna serrando a fondo le ghiera (1;2)
- Fissare la base (5) alla superficie mediante viti e tappi ad espansione (non forniti in dotazione)
- Togliere la pellicola protettiva dal cilindro dello schermo (6) e posizionare il cappello di copertura

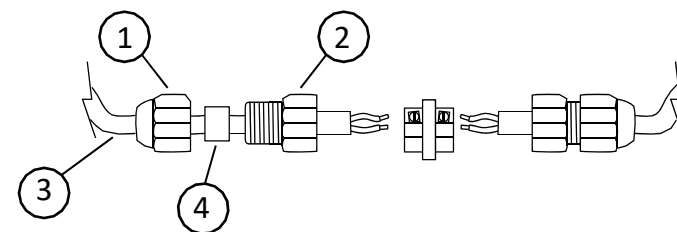
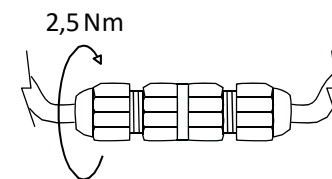
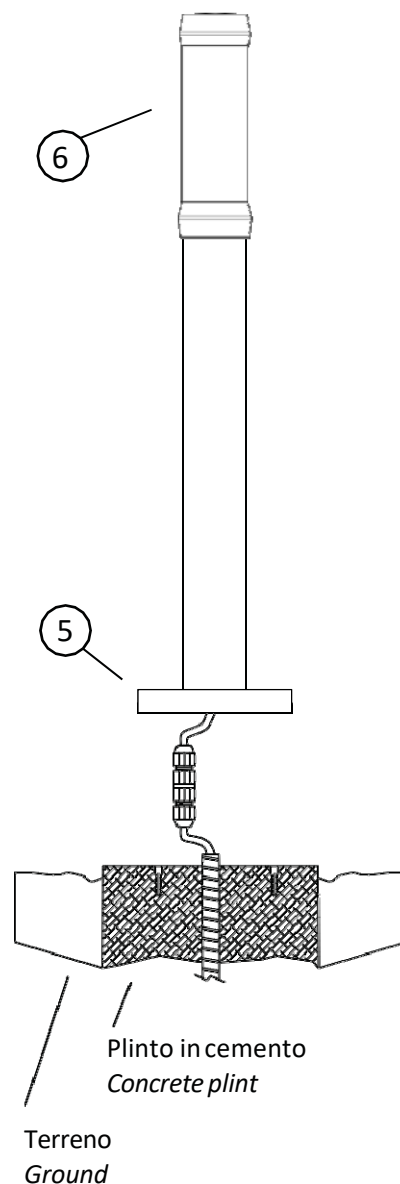

Assembly instructions

krila[®]
design

WARNINGS:

- THE INSTALLATION AND THE MAINTENANCE OF THE PRODUCT MUST BE DONE BY PROFESSIONAL INSTALLERS.
- THE SAFETY OF THE PRODUCT IS GUARANTEED ONLY WITH THE APPROPRIATE USE OF THESE INSTALLATION INSTRUCTIONS WHICH MUST BE RETAINED.
- SWITCH OFF THE ELECTRICITY BEFORE CONDUCTING ANY KIND OF MAINTENANCE.
- THE BASE AND THE OTHER PARTS OF THE PRODUCT CAN NOT BE COVERED BY SOIL OR PUT IN CONTACT WITH AGGRESSIVE CHEMICAL SUBSTANCES (HERBICIDES, FERTILIZINGS, ETC..).
- DO NOT REST OBJECTS ON THE DIFFUSER, DO NOT COVER OR OBSCURE IN ANY WAY.
- CLEAN PERIODICALLY THE PARTS COVERED BY SOIL.
- USE ONLY SUPPLY CABLES WITH DOBLE SHEATH, DO NOT USE SINGLE CABLES.
- USE ONLY FLEXIBLE CABLES (E.G. "HAR" TYPE), OR CABLES SUITABLE FOR OUTDOOR.
- IT IS FUNDAMENTAL THAT EARTH CABLE IS CONNECTED IN THE APPROPRIATE PART OF THE TERMINAL BLOCK AND THAT THE EARTH CABLE IS CONNECTED TO THE ELECTRICAL SYSTEM.

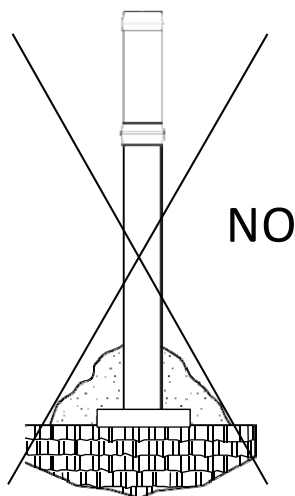
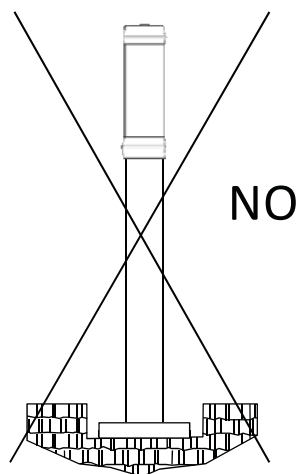

IP65      

I prodotti sono coperti da brevetto
Products are covered by patent

Online

Cod.5016/5017/5018/5019
ONLINE d.70 (h550/690/1000/1500)
Colonnina da esterno
Outdoor lamp

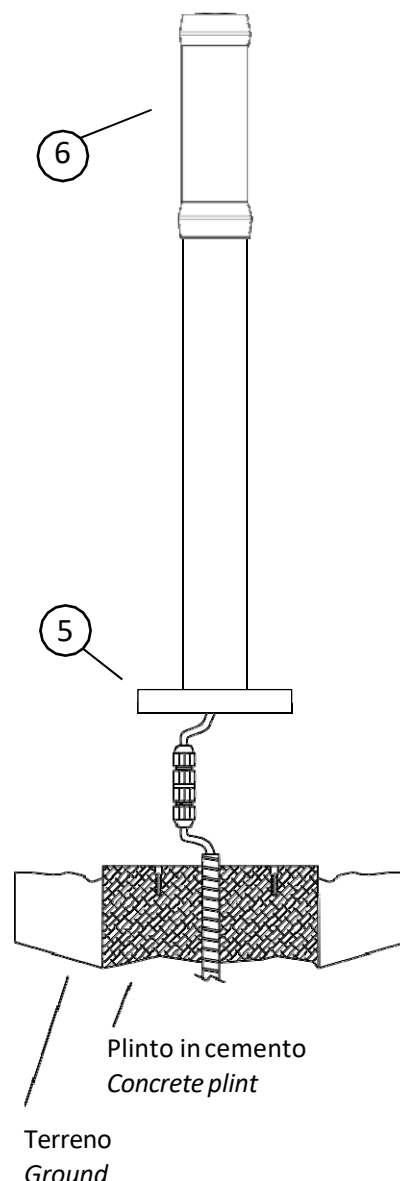

Installation instructions

- Untighten the cord blocks **(1;2)**
- Insert the supply cable **(3)** into the cord blocks **(1;2)**
- ATTENTION** : use a d.7/12 mm, cable. If you use a cable with a diameter bigger than 9 mm remove the inner gasket **(4)** located into the cable gland
- Connect the supply cable **(4)** paying attention to respect polarities
- Close the watertight terminal block by tightening the cord blocks tightly **(1;2)**
- Fix the base **(5)** to the mounting surface through some screws and expansion caps (not included)
- Remove the protective layer from the cylinder **(6)** and position the top

